

HITZE SIGA OPERATION AND INSTALLATION MANUAL

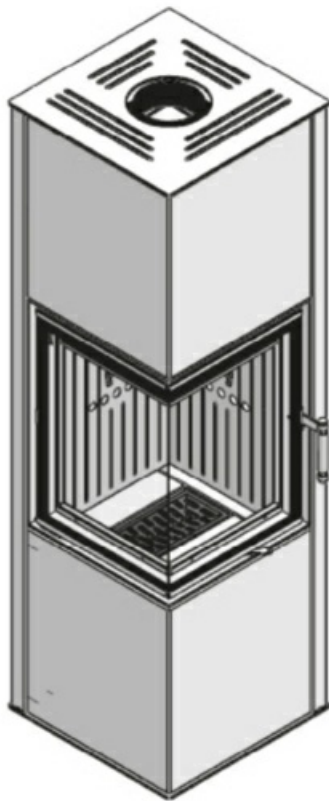

Quick Links

[Installation of the Stove](#)

Table of Contents

Table of Contents

INTRODUCTORY INFORMATION

General information

Please observe the safety rules

Never

HITZE is released from civil and criminal liability in case when

Intended use of the stove

Structure and operation of the stove

TRANSPORT, ASSEMBLY AND INSTALLATION OF THE STOVE

Transport

Assembly

Recommendations concerning the floor

Chimney duct

Connection to the chimney duct

The combustion gas outlet system should have the following features

Ventilation of the stove

Installation of the stove

START-UP

Getting ready for the start-up

Lighting the stove

USE

Types of fuel

Refuelling

Preventing the escape of combustion gases

Keeping the glass pane clean

Removal of ash

General comments

MAINTENANCE

Periodic cleaning of the stove

Chimney and flue cleaning

TROUBLESHOOTING

The most frequent malfunctions and ways of eliminating them

NAMEPLATE

INSPECTION RECORDS

Other ManualsLib Projects

HITZE

PRODUCER OF FIREPLACES

OPERATION AND INSTALLATION MANUAL

Freestanding stove **SIGA**

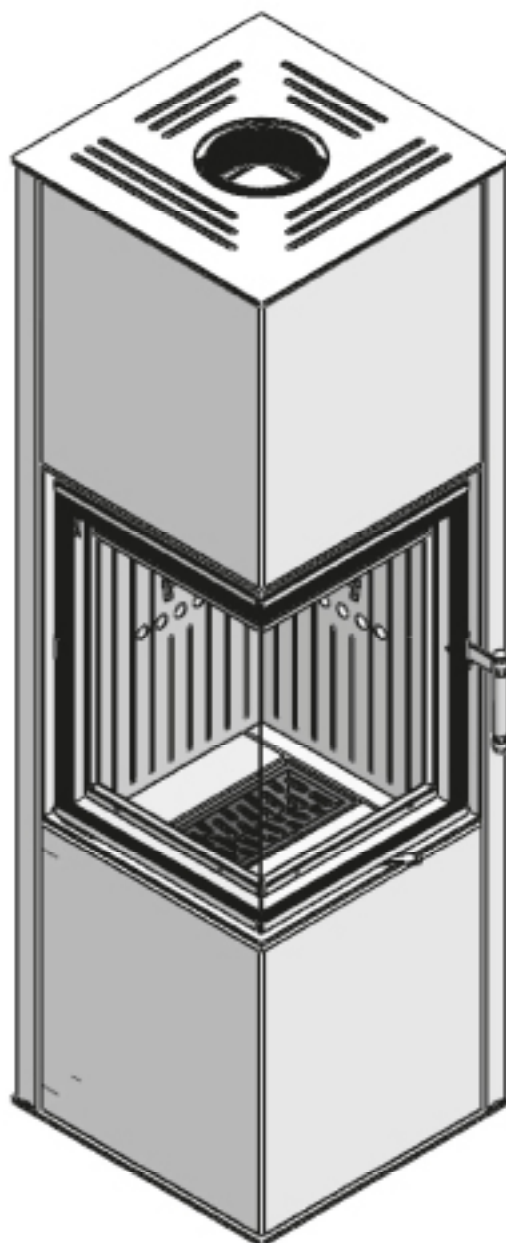

In accordance with the requirements
of the Ecodesign Directive
in the EU Member Countries:
"This product cannot be used
as a basic source of heating"

www.hitze.pl

Dear Customer,

Thank you for buying Hitze product!



BEFORE INSTALLING AND CONNECTING THE STOVE TO THE HEATING SYSTEM,
IT IS ABSOLUTELY ESSENTIAL TO BECOME FAMILIAR WITH THE **OPERATION**
AND INSTALLATION MANUAL AND CHECK IF ALL COMPONENTS ARE INCLUDED.

Table of contents

1. INTRODUCTORY INFORMATION	2
1.1. General information	2
1.2. Please observe the safety rules	2
1.3. Never	3
1.4. HITZE is released from civil and criminal liability in case when	3
1.5. Intended use of the stove	3
1.6. Structure and operation of the stove	4
2. TRANSPORT, ASSEMBLY AND INSTALLATION OF THE STOVE	5
2.1. Transport	5
2.2. Assembly	6
2.3. Recommendations concerning the floor	8
2.4. Chimney duct	9
2.5. Connection to the chimney duct	9
2.6. The combustion gas outlet system should have the following features	10
2.7. Ventilation of the stove	11
2.8. Installation of the stove	11
3. START-UP	12
3.1. Getting ready for the start-up	12
3.2. Lighting the stove	12
4. USE	13
4.1. Types of fuel	13
4.2. Refuelling	13
4.3. Preventing the escape of combustion gases	14
4.4. Keeping the glass pane clean	14
4.5. Operation in adverse weather conditions and in the transition period	14
4.6. Removal of ash	14
4.7. General comments	15
5. MAINTENANCE	15
5.1. Periodic cleaning of the stove	16
5.2. Chimney and flue cleaning	17
6. TROUBLESHOOTING	19
6.1. The most frequent malfunctions and ways of eliminating them	19
7. NAMEPLATE	20
8. INSPECTION RECORDS	21

1. INTRODUCTORY INFORMATION

Natural heating – these words perfectly reflect the philosophy of HITZE brand. In line with this philosophy, we produce fireplaces and stoves fired with wood or wood pellets, i.e. the raw materials which are the least harmful for the environment. Using a state-of-the-art technology, we have created innovative solutions offering modern designs and high heating efficiency.

Our products have been designed to provide you with trouble-free operation and cosy warmth!

Before installing and connecting the stove to the heating system, it is absolutely essential to become familiar with the Operation and Installation Manual and check if all components are included.

The information contained in the Operation and Installation Manual is crucial for ensuring the correct functioning of the stove, and thus eliminating the risk of damage and accidents caused by improper use.

In the case of doubts or operation-related problems, contact your purchase point or the Manufacturer.

NOTE:

This device must not be used by children.

Never leave your children or animals unattended when the fire is burning or when the stove is still hot.

Use protective gloves to open the door of the stove after and during use.

Danger of burns (the glass and parts of the stove installation can be very hot).

In order to improve the product, the Manufacturer reserves the right to make changes in drawings, photographs and descriptions or to modify the parameters of equipment without notice at any time. The Operation and Installation Manual may not be copied as a whole or in part without prior consent of the Manufacturer. Please make sure that the Operation and Installation Manual is stored out of reach of children.

If the Operation and Installation Manual is destroyed, lost or damaged, contact your purchase point or the Manufacturer and provide the identification data of your device to obtain a replacement copy.

1.1. General information

Safety

Compliance with the Manual is essential for ensuring the correct functioning of the stove and avoiding damage and accidents caused by improper use.

1.2. Please observe the following safety rules:

- before installing the stove or performing any maintenance work on it, make sure that you have read and understood the Operation and Installation Manual;
- the stove should be installed at the most convenient location and in conformity with the applicable construction and fire prevention laws;
- installation, maintenance and operation control activities may only be performed by qualified specialists;
- the device may only be used in accordance with its intended purpose;
- a clothes dryer may be placed at least 1.5 m away from the stove (to minimize the risk of a fire);
- check the permissible load carrying capacity of the substructure (floor, ceiling) at the intended location of the stove (taking into account the total weight of the stove and its encasing);
- provide an appropriate chimney installation to ensure safe operation (e.g. chimney made from non-combustible materials with poor heat-absorbing properties);
- avoid installation in rooms with B type gas devices, hoods (with or without exhaust), heat pumps, collective ventilation conduits or multiple flue pipes;
- the stove must not be fitted in the vicinity of the staircase or rooms with appliances capable of creating negative pressure;

- avoid direct contact with the stove (it becomes very hot during use) and wear suitable protective equipment (protective clothing or heat-resistant gloves);
- install the stove in a room equipped with appropriate firefighting equipment and all utilities, including air, water, electricity and smoke outlets;
- if you encounter any problems, please contact your point of purchase or the Manufacturer (and always request original spare parts for repairs);
- check and periodically clean the combustion gas outlet pipe in accordance with the applicable provisions of law;
- if the device is sold or lent to another user, make sure to enclose the Operation and Installation Manual.

1.3. Never:

- lean on the stove or climb onto it;
- use the appliance in the event of fault or malfunctioning;
- place flammable materials closer than 1.5 m to the stove;
- light the fire with flammable materials or burn waste in the stove.

1.4. Hitze is released from civil and criminal liability in the case when:

- when the stove is not used in accordance with the Operation and Installation Manual;
- the stove is modified or its parts are replaced with non-original parts in an authorized manner (any such modification or replacement immediately renders the guarantee null and void);
- incorrect installation or improper maintenance (non-compliant with the Operation and Installation Manual) lead to injuries or damage to property.

1.5. Intended use of the stove

Stoves of SIGA series are intended for use as an additional source of indoor heat. They are equipped with a periodical hearth and manual loading of fuel, and are closed with a standard (hinged) door. The stoves are fueled with the seasoned wood of deciduous hardwood (birch, hornbeam, beech) of humidity below 20%. During the burning process, thermal energy is released and transferred from the combustion chamber by conduction and radiation.

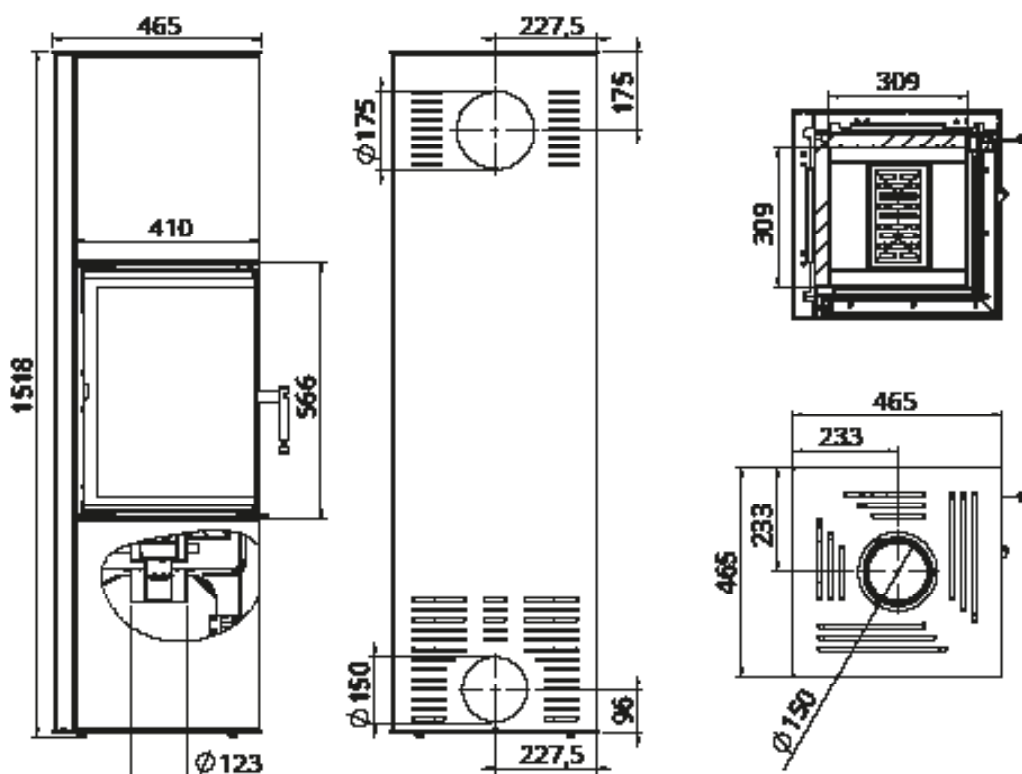

Fig. 1 Dimensions of the stove

Tab. 1 | Technical data

parameter	unit	SIGA
Nominal power	kW	6,5
Heating load range	kW	3-8,5
Max. fuel load	kg	2
Average fuel consumption	kg/h	1,9
Thermal efficiency	%	84
CO emission (at 13% O2)	g/m3	0,948
Dust emission (at 13% O2)	g/m3	0,026
Average temperature of fumes	°C	190
Glass dimensions	mm	381x530x381
Max. log length	mm	300
Weight	kg	179
Fuel type	recommended seasoned deciduous wood (beech, birch, hornbeam)	
Fuel moisture	between 12 and 20 %	

1.6. Structure and operation of the stove flue

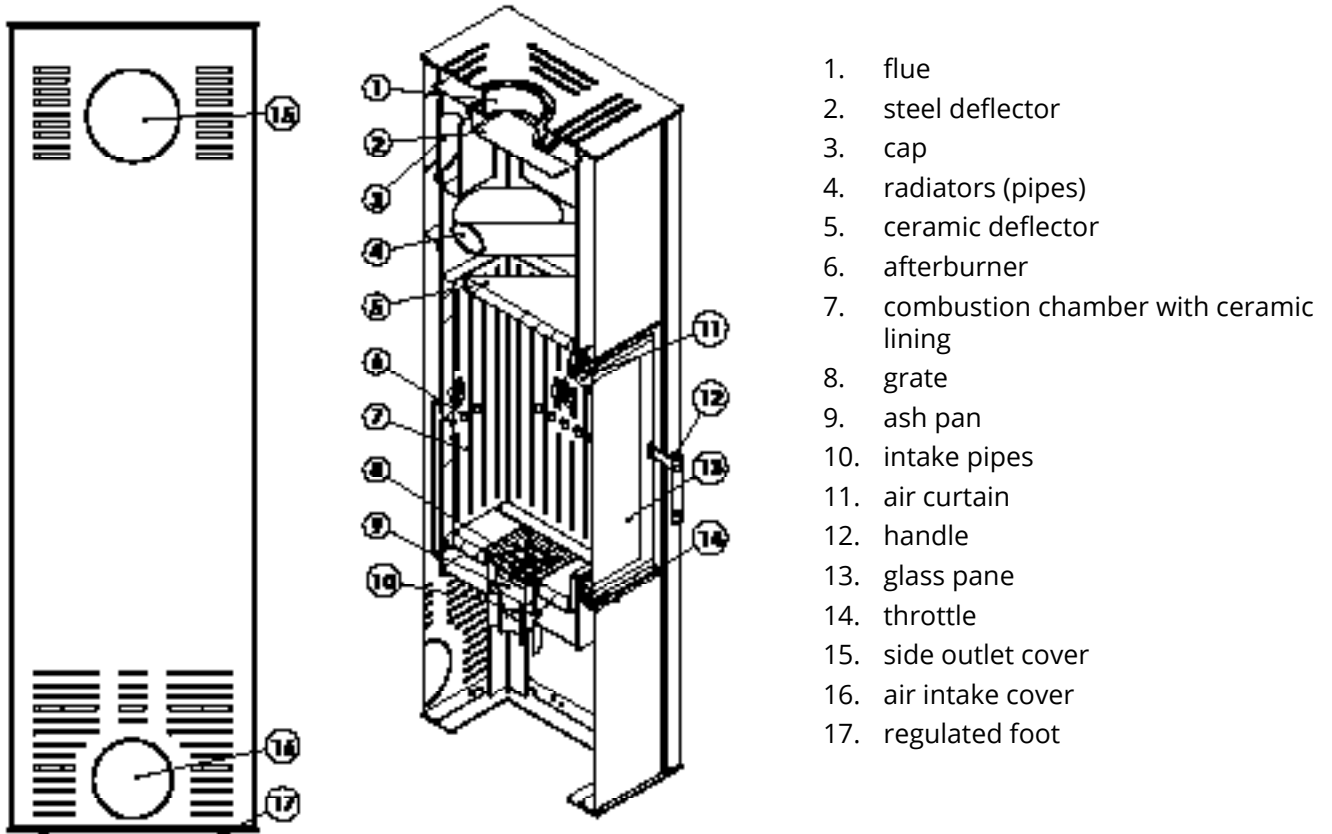

Fig. 2 | General structure of the stove

Structure:

The stove is made of 3 mm thick P265GH boiler steel. The interior of the stove is lined with a heat accumulating ceramic lining **7**. The construction of the stove enables the combustion gases to escape through the upper or rear wall. The air inlet **10** has a diameter of 123 mm, flue **1** has a diameter of 150 mm. The front of the stove consists of steel door made of special profile and profiled metal sheet, heat resistant glass pane **13**, and a handle **12**. The door is screwed to the bars which are fastened to the body of the stove.

Description of the operation:

The air enters the furnace through the inlet **10**. Inside, there are two air intake systems - primary and secondary. The amount of incoming primary air is controlled via the lower intake throttle located on the front of the stove under the door **14**. Then, the air flows around the ash pan **9**, and through the grate **8** it enters the combustion chamber **7**. The amount of the secondary air is unregulated. The air is directed to the upper part of the combustion chamber **6**. The amount of the air is regulated by moving the lever to the left to open the air supply, and the right to close the air supply.

The stove is also equipped with an air curtain **11** to help maintain the clean glass. Above the combustion chamber, there is a special ceramic plate called deflector **5**, which enhance the thermal exchange. During burning, hot gases float over the deflectors and then through the flue **1** and the duct they go to the chimney. The surrounding around the stove is heated in two ways - the air surrounding the stove is heated (convection) and exits through the ventilation slots in the stove encasing. In addition, the heat radiates directly from all hot parts of the stove.

2. TRANSPORT, ASSEMBLY AND INSTALLATION OF THE STOVE

The device is compliant with the PN-EN 13229:2002 standard and has a CE certificate.

Before assembling, installing and using the freestanding stove, read the Operation and Installation Manual carefully and follow the instructions contained in it. It will ensure safe and efficient operation of the stove. Non-compliance with this Operation and Installation Manual may invalidate the guarantee and put the user at risk of injury or loss of life.

The product must be assembled, installed and used in accordance with the national and local laws and standards, including in particular:

- Regulation of the Minister of Infrastructure of 12.04.2002 Dz.U. [Polish Journal of Laws] No. 75, item 690 amended on 07.05.2004 Dz.U. [Polish Journal of Laws] No. 109, item 1156;
- PN - B - 03406 Standard: 1994 Heating engineering. Calculated heat demand;
- PN - 89 / B - 10425 Standard: Flue pipes, combustion gas ducts and ventilation ducts made from bricks;
- PN - 78 / B - 03421 Standard: Ventilation and air conditioning. Parameters for calculating indoor air;
- PN-EN 13229:2002 Standard "Inset appliances including open fires fired by solid fuels. Requirements and test methods".

The stove must be installed by a qualified person or company and commissioning checks must be performed by a master chimney sweep and a fire prevention specialist.

The installation of the stove should be performed in the following order:

- prepare the place where the stove will stand, check carrying capacity of the ground;
- connection of the stove to the chimney and make ventilation;
- putting the stove into use and observing its functioning for the purpose of detecting defects and anomalies (for about 2 weeks);

2.1. Transport and handling:

- the stove is delivered as an assembled unit, fastened to a palette and wrapped in stretch foil;
- the stove should be transported in a vertical position;
- after unpacking, check the stove for any transport related damage;
- unpack the stove in the vicinity of the installation site; exercise caution when moving the stove (preferably

on a cart, paying special attention to the door and glass);

- the packaging materials of the stove are not toxic or harmful and should be recycled or stored by the User;
- to facilitate the assembly of the stove in hard-to-reach places, the ceramic lining (shielding the hearth) can be removed; after the assembly, every element should be correctly placed in its intended location.

2.2. Assembly

The air inlet pipe can be connected through the lower click door of the stove.

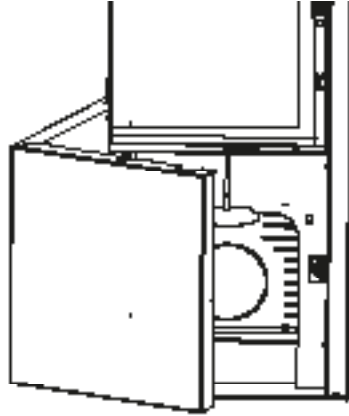

Fig. 3 | Door opening

The design of the stove allows 2 different configurations. The flue can be on the side or top wall and the side on which the flue will be located can be changed.

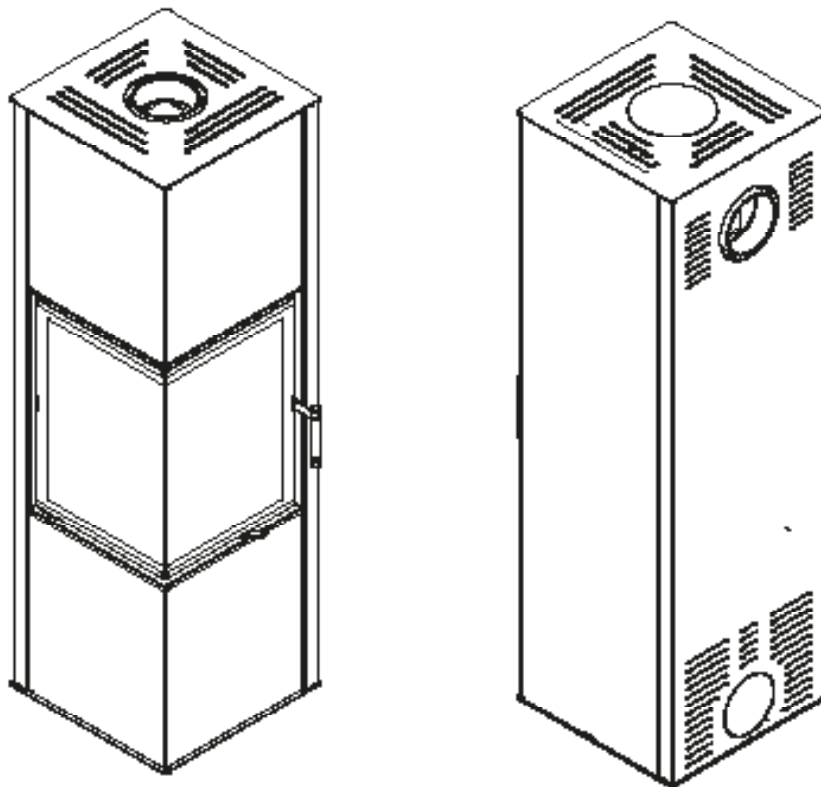
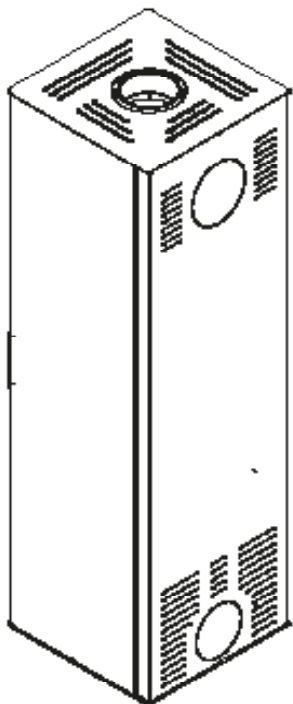
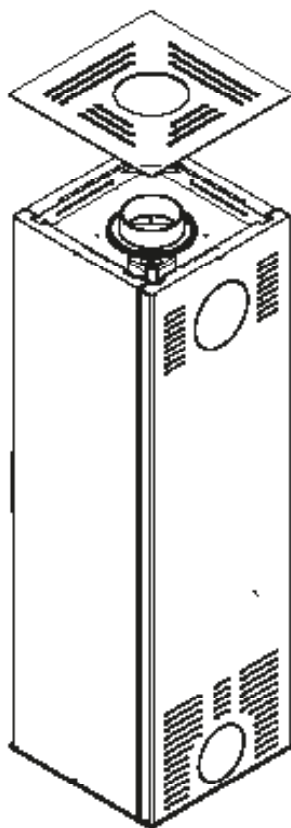

Fig. 4 | Configuration options

Operation of changing the sides of a free-standing stove.



1. stove in its factory configuration



2. lift the top cover and put it aside somewhere safe

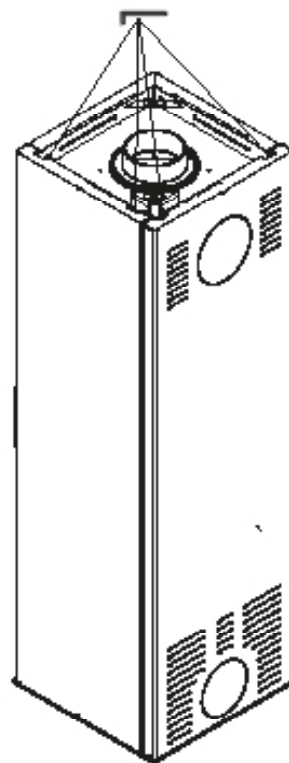

3. use Allen key to unscrew the screws holding the covers

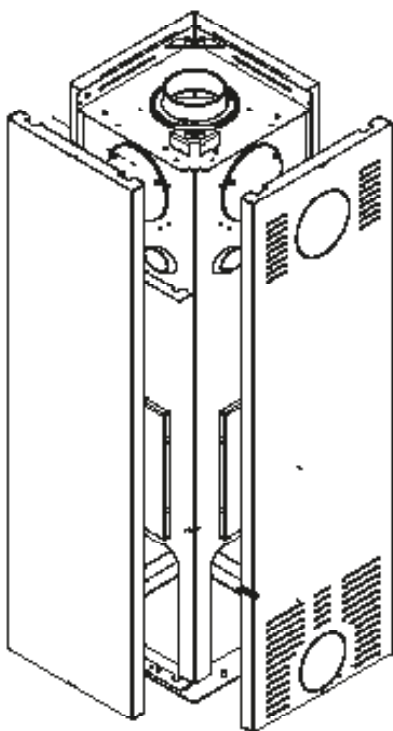

4. remove the covers from the bottom hinges by lifting them up

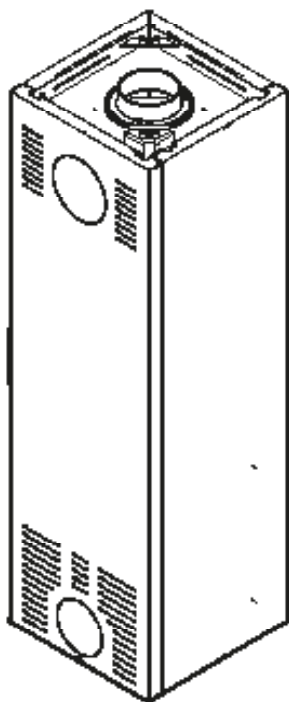

5. swap the covers with their places, put it back on the hinges and screw on

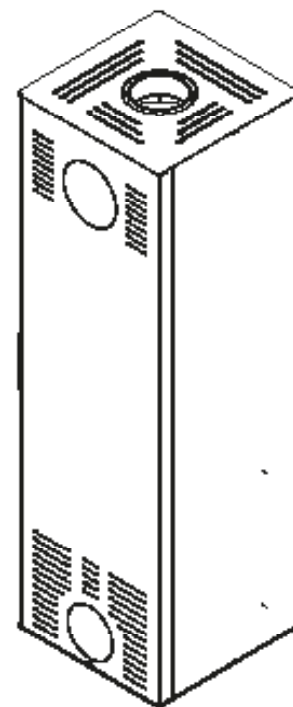

6. put the top cover back on the stove

Moving the flue from the top of the stove to the side.

Steps from **1-4** should be followed and then:

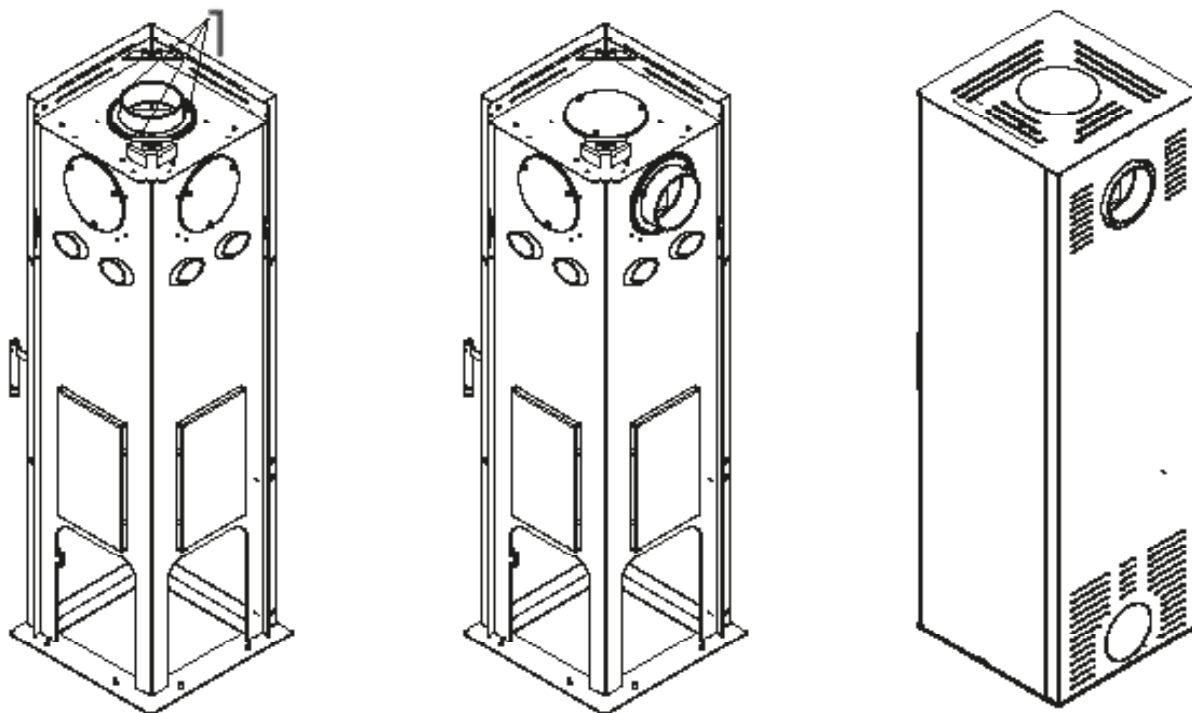

7. use an Allen key to unscrew M6 screws holding the cast iron flue and cast iron lid of the stove

8. swap the flue with the lid

9. mount the side walls back (make the whole for the flue in the side cover) and put the top lid and the cast iron caseback

2.3. Recommendations concerning the floor:

- before installing the stove, check the load-bearing capacity of the floor (to make sure that it is sufficient to bear the weight of a given type of appliance);
- the floor must be made of non-flammable material with a minimum thickness of 30 cm; a safety area of least 60 cm must be ensured in front of the stove door, and of at least 30 cm from the edges of the door.

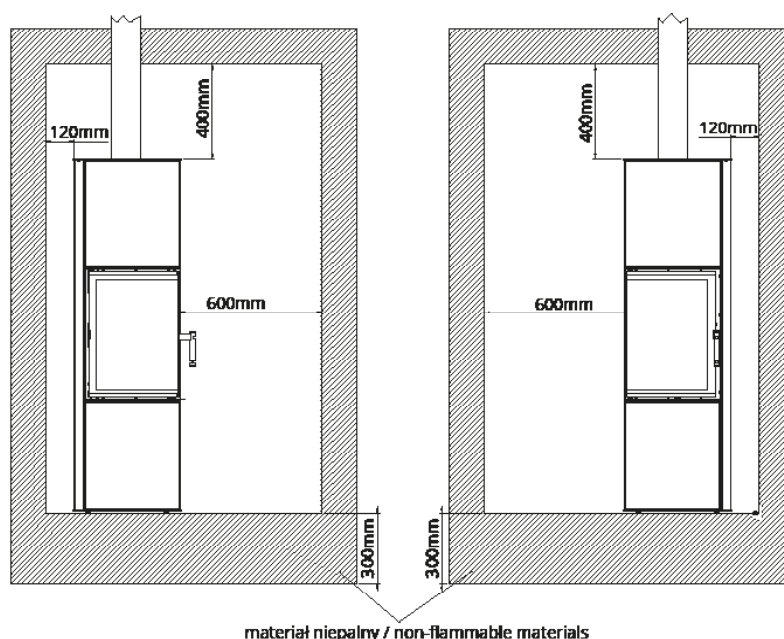

Fig. 5 Recommendations concerning the floor and surrounding

2.4. Chimney duct

The stove must be appropriately selected to match the cross section of the combustion gas duct (flue pipe) and the height of the flue.

The cross-sectional area of the flue and of the combustion gas duct is calculated in accordance with the following formula:

$$F = \frac{0.003 \times Q}{\sqrt{h}} \quad [\text{m}^2]$$

where:

F – cross-sectional area of the flue and of the combustion gas duct [m²];

Q – rated thermal input [kW];

h – the height of the chimney [m].

In accordance with the applicable provisions of law, the flue may not be smaller than 14x14cm or its diameter must be 15cm. Stoves with a higher thermal input require a flue with a larger cross section. The cross section also depends on the height of the chimney.

The stove should be connected to the combustion gas duct or the vertical duct in accordance with the applicable national standards.

The chimney draught should be as follows:

- minimum draught – 6 ± 2 Pa;
- **MEDIUM, RECOMMENDED DRAUGHT – 12 ± 2 Pa;**
- maximum draught – 15 ± 2 Pa.

NOTE:

To ensure the correct functioning of the stove, there must be a correct chimney draught in the connector of the flue pipe:

- the stove will not function properly if the chimney draught is not sufficient, resulting in excessive soot deposits on the glass and in combustion gas ducts and reducing the total thermal power of the stove (due to which combustion gases may escape to the room);
- if the draught is too strong, the burning process may be too intense, causing high consumption of fuel and resulting in permanent damage of the stove.

The chimney should be regularly inspected by a chimney sweep company.

2.5. Connection to the chimney duct:

- before installing the stove, the chimney ducts and its technical parameters and condition must be inspected and approved by a chimney expert;
- the stove may be only installed after the flue pipe has been inspected and approved by a chimney expert.

The chimney duct must satisfy the applicable national or European standards.

The stove must be mounted and connected to the chimney in accordance with the supplied Operation and Installation Manual (together with the deflector plates - if they are to be used, and the insulation of the flue pipe).

The manufacturer **does not recommend** the assembly and installation of the appliance by the user on his or her own. To make sure that the stove is installed and put to use in a correct and safe manner and to satisfy the guarantee conditions, the user should have the appliance installed and put to use by a qualified installer or an installation company. The installer is required to confirm in the guarantee card (signature and stamp) that the stove has been installed in accordance with good building practices and the applicable legal provisions. If the above-mentioned activities are not performed, it will invalidate the guarantee.

2.6. The combustion gas outlet system should have the following features:

- the cross section of the flue pipe may not be smaller than the cross section of the chimney duct and it may not become narrow towards the chimney (between the flue pipe and the chimney, the diameter can be increased through the use of mounting adapters);
- the path of the combustion gas duct should be as short and straight as possible (bends increase flow resistance and facilitate the accumulation of condensed moisture);
- it is forbidden to connect the stove to the same chimney duct with another heating device;
- the stove should be connected to its own chimney duct;
- the combustion gas duct may not have more than two inclinations of 45° when its length does not exceed 5 m and of 20° when it is more than 5 m long;
- the combustion gas duct must be made from non-combustible materials and it must be thermally insulated;
- the insulation of the flue pipe must ensure fire resistance for at least 60 minutes;
- the flue exit should be followed by a straight pipe with a minimum length twice as long as the diameter of the stove flue;
- the connector must be leak-proof;
- the end of the chimney should ensure a trouble-free outlet for combustion gases and it should be placed at least 60 cm above the highest point of the roof;
- the connectors must be made from stainless, heat-resistant steel 1.4401 (316) or fireplace steel, painted with a special paint. The metal sheet must have an appropriate thickness (heat-resistant and stainless steel must be 1mm thick, fireplace steel - 2mm) and be resistant to high temperature, the acidity of combustion gases and condensed moisture.

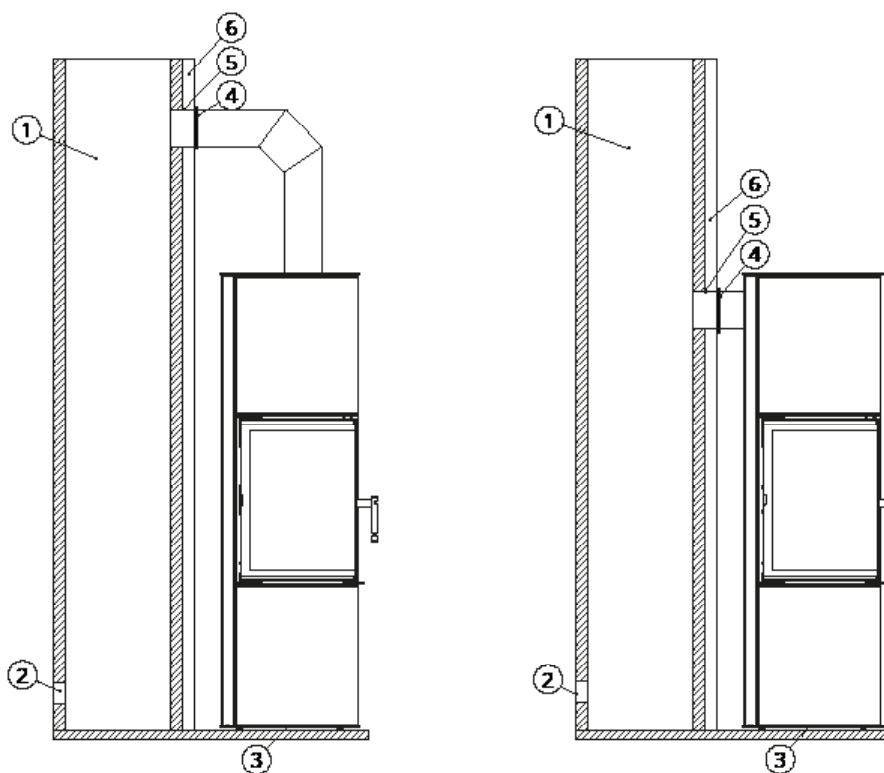

1. chimney duct,
2. cleaning window,
3. the intake of cold air from outside,

4. rosette,
5. sealing mortar,
6. non combustible material.

Fig. 6

The scheme of connection of the stove to the chimney duct

2.7. Ventilation of the stove:

- **it is necessary to bring fresh air from the outside through unsealing the windows so that there is a constant supply of the air. Too small amount of fresh air from the outside can cause poor combustion (production of carbon monoxide), and in the worst case, with tightly closed windows, the air can escape with carbon monoxide through the ventilation ducts and there is a risk of smoke poisoning;**
- the construction of the stove enables the supply of the fresh air (the air is supplied by throttles) directly from the room where the furnace is located, while ensuring adequate ventilation against automatic closing of the air supply from the outside;
- it is estimated that about 8m³ of air is required for burning 1kg of wood;
- in the case of using a system of distributing air to other rooms, it is essential to ensure the return of cooled air to the room where the stove is installed so that the air can circulate freely (otherwise, the work cycle of the stove may become disrupted, which will hinder the distribution of warm air);
- when choosing the site for the appliance and during its installation, attention should be paid to ensuring the correct circulation of air and a proper balance between air flow in the room;
- ventilation must be provided in the room where the stove is installed;
- to ensure adequate convection space (stove cooling, air heating), the stove should be placed at least 80cm from materials that could be deformed or damaged by high temperature (furniture, paneling, wallpaper, etc.).

ATTENTION!

- the best way to ensure the right amount of air to the stove is to bring it through a special air supply duct directly from the outside of the building located under the floor;
- it is also possible to connect the stove to the inlet located in the wall of the building using fireproof pipes;
- when using close inlet distances to the insert, we recommend turning the pipe under the stove before connecting it to the air intake, so that the cold air has time to heat up before entering the combustion chamber;
- care must be taken to ensure that cold air from the outside does not lead to condensation of warmer air on and in the air intake pipe or the furnace, which may cause an increase in moisture in the furnace chamber. This can lead to rapid corrosion of the stove;
- to prevent this phenomenon, we can connect the stove at a slight slope to the outside, insulate the air supply pipe and use an additional damper closing the air intake when the fireplace insert is not in use;
- in the case of too strong draft that does not allow for combustion regulation, an additional damper should be used to additionally protect the fireplace insert against the inflow of too much air into the combustion chamber when the stove is used or completely close the air supply when it is not in use;

Failure to meet the above conditions may lead to improper operation of the stove, its corrosion or problems with air regulation that are not subject to complaint.

2.8. Installation of the stove

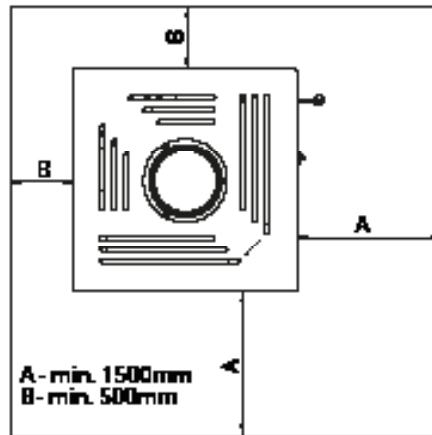

Fig. 7 Safe area for flammable materials

The appliance must be installed in accordance with the applicable provisions of the building law.

The stove must be installed and assembled by qualified specialists.

To ensure the correct installation:

- the stove must be placed at a safe distance from any flammable materials (the walls or other surfaces surrounding the stove may have to be secured);
- the space in front of the stove must be protected against sparks that may fall out of the furnace during adding fuel. The minimum safe area is 60cm in front of the stove and 30cm from the edge of the door. Surfaces can be protected with natural stone, floor tiles or a dedicated glass base;
- it is forbidden to install the stove in a bedroom, bathroom or in a room with another heating device without its own air intake;
- it is not permitted to integrate the stove with an air recuperation system;
- the stove is a standalone device and does not require any additional supports;
- the stove is equipped with regulated feet for adjusting the height (levelling) of it (with an adjustment range of up to 20 cm);
- if the stove has to be raised above the adjustment range of the feet, make a brick base and place the stove on it (do not remove the feet as they are needed for levelling purposes);
- incorrect levelling of the stove will hinder the functioning of the door (it will not close properly);

3. START-UP

After the stove has been mounted and connected to the chimney, the first start-up of the stove must be performed by an installer or a qualified service technician. As part of the start-up procedure, the installer should show the User how to operate the stove correctly. The installer is obliged to refuse to put the stove into use if he or she finds any assembly-related irregularities which make it unsafe to use. A correctly performed start-up should be confirmed in writing in the guarantee card.

3.1. Getting ready for the start-up

Before lighting the stove for the first time, it is necessary:

- to remove any labels, paper stickers and accessories from the body of the stove or hearth to eliminate the risk of fire; the same applies to transport safety devices;
- to check if the deflector/s, ceramic fittings are mounted correctly and were not dislodged from their correct position during installation (any discovered mounting errors must be corrected). Non-removal of such errors may hinder proper functioning of the stove. In the case of stoves with multi-pane glass doors, it should be checked if particular glass panes did not become loose during transport or use;
- to check the operation of:
 - mechanism regulating the air inflow into the combustion chamber (cold air inflow throttle);
 - front door closing mechanism (hinges, handle);

3.2. Lighting the stove

Before lighting the stove, please do the following:

- arrange a stack of firewood in the hearth, starting with larger pieces of wood, followed by medium-sized pieces of wood and then by small chips of wood for fire lighting – light it with a match;
- set the primary air regulator in the fully open position and the secondary one in the minimum;
- after lighting the fire, the door of the stove must be closed;
- when the fuel is burning properly, adjust the burning process with air regulators to ensure a steady and calm rate of burning (this causes only a small portion of the primary air to be fed under the oven grate; secondary air throttle to max - more air is fed into the air curtain system, protecting the glass from sooting and to the gas afterburning system in front of the cartridge; opening the air damper at 100% - maximally to each other, causes very intensive combustion of fuel);
- it is recommended, at the final stage of burning, to open the door and move the remaining embers onto the grate, using a poker, so that all fuel is used up;
- test the functioning of other components of the installation (when the fire is lit for the first time).

NOTE:

Because of too big amount of air is fed under the grate and to the after burning system, too much fuel in the combustion chamber causes the production of a large amount of wood gas and the glass pane may become temporarily covered with soot.

When the mechanism is moved to its rightmost position, it will completely cut off the inflow of air to the combustion chamber and the fire will be gradually put out.

If the grate needs to be unclogged, stir accumulated ash with a poker or the lever of the grate.

During the first hours of using the stove, it is recommended to load the stove with a small amount of fuel, i.e. up to 50% of the normal load.

When the stove is lit for the first time, water may condense on the internal walls of the combustion chamber. This phenomenon is normal and is caused by the condensation of water vapour contained in combustion gases. It should disappear after the combustion chamber has heated up.

If combustion gases escape from the stove chamber, the position of the combustion gas throttle should be adjusted and the chimney draught should be increased.

Before the next lighting, clean the hearth from remaining ash.

4. USE

The surface of the stove is covered with a special heat-resistance paint. After lighting the stove, this paint initially becomes soft (care must be taken not to scratch it then) and then hardens. Due to this process, an unpleasant smell is produced when the stove is lit for the first few times. It is recommended to make sure that the room is well aired during that time. If pets or birds are kept in the room, they should be temporarily moved to another place. In the initial stage of using the stove (for about 2 weeks), the manufacturer recommends maintaining a small flame by burning a smaller quantity of fuel at a lower temperature. This method of lighting the stove is intended to prevent cracks in the ceramic lining, to avoid deformation of the stove

structure or damage to the protective (paint) layer of the stove.

4.1. Types of fuel

Considering the design of our appliances, the most suitable type of fuel is the deciduous hardwood, including: oak, hornbeam, ash, beech, birch. In particular, we recommend using birch wood. The best fuel is wood which has been seasoned (for at least two years in a well-ventilated and dry place), cut and chopped into logs. We advise against using the wood of coniferous trees. Freshly cut or damp wood is not a good fuel because it has low calorific value. The burning of insufficiently dried wood may result in increased deposits of creosote in the combustion gas ducts, which may cause overheating the stove and the glass panel to break.

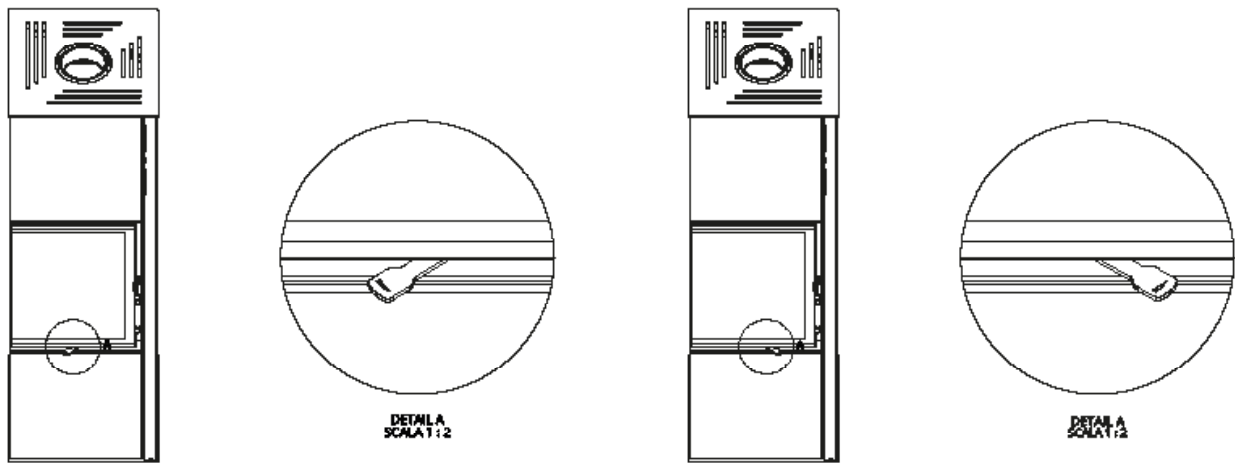

Fig. 8 Throttle operation - moved to the right - air supply closed, moved to the left - air supply open.

NOTE:

It is forbidden to burn waste fuel, liquid fuels and other types of fuel not recommended by the manufacturer of the stove.

It is strictly forbidden to use the following as fuel for the stove: bituminous coal, the wood of tropical trees, all types of products containing chemical compounds such as petrol, alcohol, naphthalene, oil, waste and laminated panels containing adhesives.

4.2. Refueling:

- fuel should be added when flames disappear over the layer of embers in the hearth; it is best to heap embers into a pyramid-like shape onto the grate (from both sides, to ensure a sufficient flow of air from underneath the grate for flames to appear) and then add slivers of wood;
- embers should not be heaped over the grate in an even layer because it would significantly reduce the flow of air from under the grate and result in a build-up of gas in the hearth chamber and in the whole stove, which might lead to an explosion;
- wooden logs in the combustion chamber should be arranged in parallel to the plane of the door;
- before loading the hearth with a new portion of wood, remove ash from the grate and empty the ash pan if necessary.

4.3. Preventing the escape of combustion gases

To prevent the escape of combustion gases from the stove to the room during the opening of the door, it is recommended to:

- set the primary air regulator in the fully open position for about 10 seconds before opening the door (lever moved to its leftmost position);
- move the door slightly partly open, wait a few seconds (until combustion gases disperse) and then slowly

open the door of the stove;

- exercise caution when opening the door and after opening it because burning pieces of wood may fall from the hearth;
- after adding an appropriate quantity of fuel, close the door of the hearth;
- when the fuel is well alight, set the air regulator in its original position;
- the optimum amount of fuel for 6,5 kW stove is 1,9 kg/h.

NOTE:

Take care not to overload the stove with fuel. Overloading may cause permanent damage to its structure.

4.4. Keeping the glass pane clean

The cleanliness of the glass pane depends on using appropriate fuel, as well as on:

- supplying a sufficient quantity of air for the burning process;
- optimum chimney draught;
- the method of operating the stove;
- the use of fuel with a moisture content no less than 20%.

To keep the glass pane clean, it is advised to add the recommended quantity of fuel and to position it centrally on the grate and as far from the glass panel as possible.

In the case of a build-up of tar on the glass pane, we recommend increasing the intensity of the burning process by opening the throttle and the glass pane should normally clean automatically.

4.5. Operation in adverse weather conditions and in the first period of use

In the first period of use or in adverse weather conditions (e.g. during a fog, on damp and rainy days, in weather with strong gusty winds or when outdoor temperature exceeds +15°C), the chimney draught may become too weak to remove all combustion gases. To offset this negative effect, the stove should be loaded with the smallest possible amount of fuel or additional draught regulators should be used.

4.6. Removal of ash

Depending on the amount and type of burning fuel:

- use a poker to rake the ashes through the grate into the ash pan;
- after collecting the ash, take out the ash pan and empty it;
- the ash pan can only be emptied when it is cold; it should be done, at the latest, before lighting a new fire;
- before emptying the ash pan, make sure that it does not contain any leftover embers which might cause a fire in the waste bin.

NOTE:

Take care not to overfill the ash pan. If the ash pan is too full, it will hinder the inflow of air under the grate, hindering the burning process or, in extreme cases, even making it impossible to light the stove.

If ash remains in the ash pan too long, it may result in premature corrosion. The ash from burnt wood may be used as compost material or fertilizer.

4.7. General comments

Things to be done:

- make sure that the door of the hearth (combustion chamber) are closed (unless they need to be opened for maintenance purposes);
- prior to lighting up after a prolonged shutdown period, check the flue pipe in the chimney and the hearth to make sure that they are unobstructed and clean;
- during the performance of any maintenance or operation-related tasks, remember that the components of the stove can be very hot. Therefore, it is necessary to wear protective gloves;
- for any repairs of the stove use only spare parts produced by its manufacturer;
- all repairs must be performed by a qualified installer;
- during the operation and use of the stove, follow the basic safety rules.

It is forbidden:

- to leave any flammable materials or items sensitive to high temperature near the glass of the stove;
- to use the appliance when its glass is broken;
- to extinguish the hearth fire with water;
- to let children come near the appliance;
- to make any structural changes or to alter the rules of installation and use without prior written consent of the manufacturer;
- if any malfunctions are detected, the fire must be extinguished immediately.

NOTE:

In emergency situations, extinguish the fire by covering the fuel with sand or cold ash.

DO NOT USE WATER!

If the stove does not function correctly, any maintenance work may only be carried out after ensuring good ventilation of the rooms, as well as the assistance of another person equipped with a dry-powder extinguisher.

When the burning process is slow, large quantities of organic products of combustion are produced, which may lead to the build-up and ignition of creosote in the chimney duct. As a result, the so-called chimney fire breaks out, which may spread to the whole building.

In the case of a chimney fire, please do as follows:

- **cut off the inflow of air to the stove by closing the throttle of the cold air inlet;**
- **close the rotary damper valve of the combustion gas flue (if installed in a given model);**
- **close the door of the stove tightly;**
- **dial 112 or 998 to alert the local Fire Department.**

5. MAINTENANCE

To ensure safe and problem-free operation of the appliance, observe the following guidelines:

- perform periodic maintenance tasks in a timely manner – have the stove inspected by a specialized servicing company at least once a year;
- keep the following components clean: glass pane, combustion chamber with the ash pan and the chimney duct;
- empty the ash pan regularly - if ash remains in the ash pan too long, it may result in corrosion.;
- make sure that the combustion chamber is cleaned and serviced with a frequency which is appropriate for a given type of fuel;
- make sure that steel or cast-iron elements inside the stove are cleaned with appropriate tools such as: brush, scraper and poker; use protective gloves;
- any maintenance activities may be only performed after the fire has been extinguished and the stove has cooled down;
- clean the ceramic glass pane of the stove with a kitchen paper (paper towel). It should be moistened with

water and then collected with a bit of clean ash from the inside of the grate, avoiding direct contact with steel elements and cast-iron devices. By rubbing the glass with so prepared moistened paper, we can effectively dissolve the tarnish - so that it can be wiped with a dry paper towel. All agents used to clean the glass must not contain abrasive materials causing its damage (scratching);

- chimney ducts must be cleaned by a qualified chimney sweep company at least twice a year and it must be documented in the guarantee card;
- the inside of the stove must be cleaned and the airflow and the combustion gas outlet must be inspected;
- replace all gaskets before the heating season.

5.1. Periodic cleaning of the stove

To ensure an efficient burning process in the hearth of the stove, the combustion chamber, the grate, the flue and combustion gas ducts must be cleaned periodically.

Component	Frequency	Tools and resources
The convection surfaces of the stove and the pipes connecting it with the chimney duct – cleaning	As needed, but not less frequently than once a year or after a prolonged shutdown period	A brush made from a resilient material, vacuum cleaner, fireplace cleaning products.
Combustion gas duct, chimney - checking if the chimney is not obstructed and that the combustion gas installation is in a good condition	At least twice a year, after the heating season and after a prolonged shutdown period	Specialist chimney sweep company
Front glass pane	As needed	Cooled - moistened paper towel with a bit of clean ash, no abrasive materials causing its damage
Grate and internal components of the stove	As needed	Vacuum cleaner, fireplace cleaning products
Maintenance of the combustion gas throttle - replacement of the gaskets of the glass pane and of the hearth door	At least once a year, after the heating season or as needed, depending on the degree of wear and tear	Servicing company authorized by the manufacturer

5.2. Chimney and flue cleaning

The stoves have a detachable steel deflector above the ceramic deflector that allows you to easily and safely check the cleanliness of the chimney and allows for its possible cleaning. To do this, follow these steps:

- Remove the deflector holder and ceramic deflector from the furnace

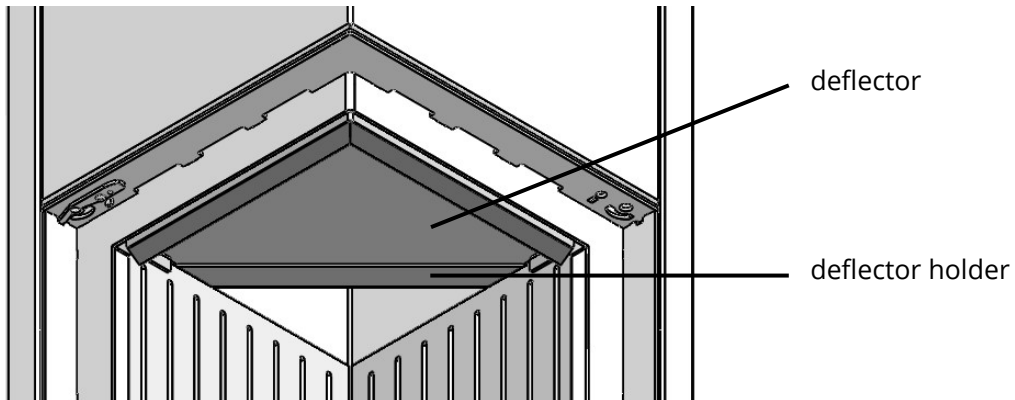

Fig. 9 Instructions for cleaning the chimney - removing the deflector

- W Depending on the connection point, unscrew the 3 M5x10 screws located behind the tubes. key

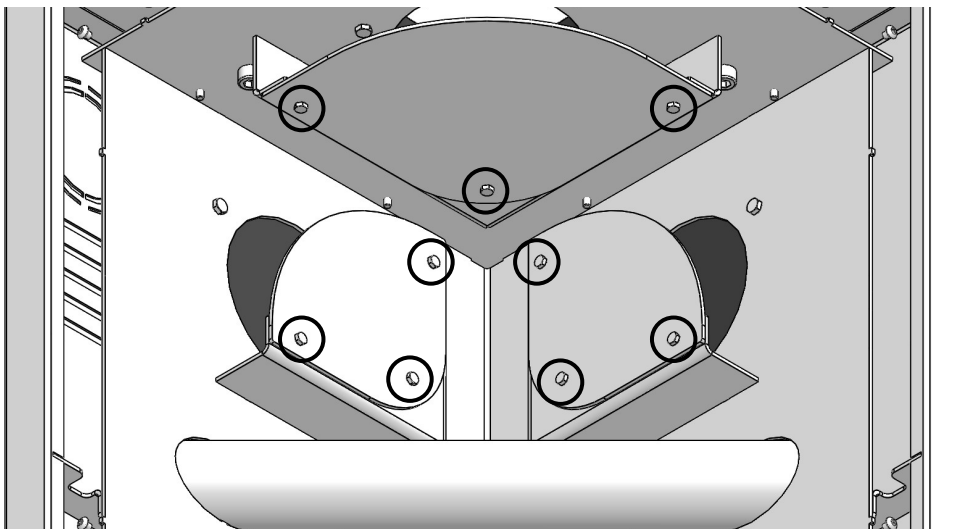

Fig. 10 Chimney cleaning instructions - unscrewing

- After unscrewing the screws, we have access to the exhaust pipes.

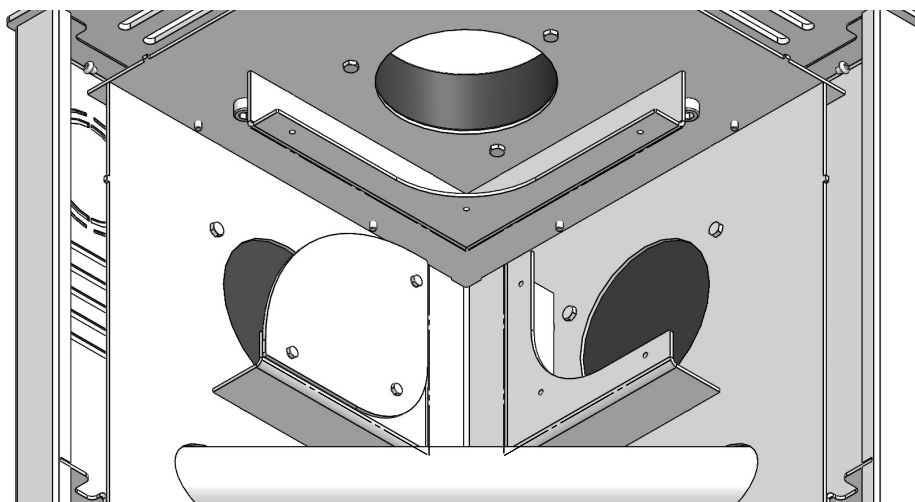

Fig. 11 Instructions for cleaning the chimney - flue pipes

6. TROUBLESHOOTING

During everyday use of the stove, the below described anomalies may become apparent in the case when the stove has been installed in a manner contrary to this Operation and Installation Manual and the applicable provisions of law.

6.1. The most frequent malfunctions and ways of eliminating them:

	Problem	Solution
Smoke escapes to the room when the door is opened	the door may be opened too abruptly, causing negative pressure in the combustion chamber	close the door slowly
	the adjustable damper valve of the flue of the chimney duct is closed (if such a valve has been installed)	open the damper valve
	insufficient amount of air in the room where the stove is installed	check the efficiency of the ventilation and make sure that the room is well aired
	weather conditions	
	inadequate chimney draught	check the efficiency of the chimney installation
The heating efficiency is low or the fire in the hearth goes out	insufficient quantity of fuel in the hearth	add as much fuel as is required
	the moisture content of the fuel is too high	use fuel with a moisture content of up to 20%
	inadequate chimney draught	check the efficiency of the chimney installation
The heating efficiency is low despite the correct burning process in the hearth	inappropriate wood with a low calorific value is used	use wood with a higher calorific value instead
	the moisture content of the fuel is too high	use fuel with a moisture content of up to 20%
	the stove has been fueled with thin and small pieces of wood which burn very quickly	place thicker logs in the stove
Soot accumulates on the glass and it does not burn off	the fuel burns too slowly and the temperature in the combustion chamber is too low	increase the amount of air in the combustion chamber, use fuel with a moisture content of up to 20%
	the stove has been fuelled with wood of coniferous trees with a high resin content	use dry deciduous hardwood instead
The appliance may be functioning incorrectly due to external factors	tall objects are situated too near the chimney	increase the height of the chimney or use a rotary chimney cowl cap or another type of chimney cowl cap
	adverse weather conditions, e.g. wind or windless weather, low atmospheric pressure, high air humidity, fog, etc.	use a chimney cowl cap and, if it does not help, seek advice of a chimney expert to establish the cause of the problem

8. INSPECTION RECORDS

REGISTER OF INSPECTIONS OF THE STOVE	
Inspection	Date, signature and stamp
Inspection	Date, signature and stamp
Inspection	Date, signature and stamp
Inspection	Date, signature and stamp
Inspection	Date, signature and stamp
Inspection	Date, signature and stamp

REGISTER OF INSPECTIONS OF THE FLUE PIPE

Inspection	Date, signature and stamp
Inspection	Date, signature and stamp
Inspection	Date, signature and stamp
Inspection	Date, signature and stamp
Inspection	Date, signature and stamp
Inspection	Date, signature and stamp



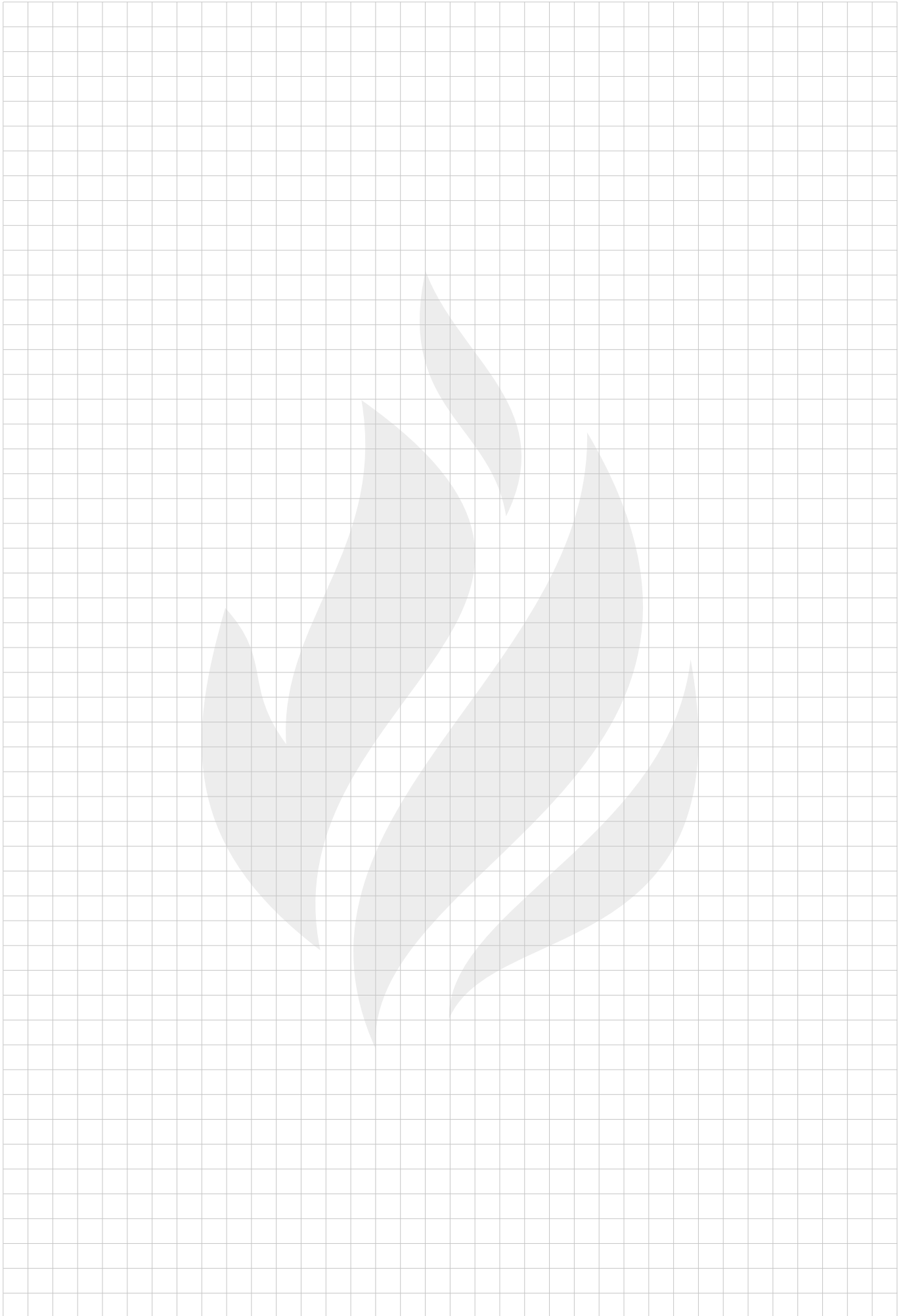



HITZE

PRODUCER OF FIREPLACES



HitzeProducentKominkow



hitze_producent_kominkow



HITZE Producent Kominków

STALKO
spółka z ograniczoną odpowiedzialnością
spółka komandytowa
ul. Solec 24/253
00-403 Warszawa, POLAND

Office:
Gdyńska 32
26-600 Radom
POLAND



+48 48 380 18 98
+48 800 88 00 30



handlowy@hitze.stalko.com
export@hitze.stalko.com
marketing@hitze.stalko.com

VAT PL9482603545
REGON 361379132
Reg. No. 0000836475

www.hitze.pl

Other ManualsLib Projects



www.manualslib.com



www.manualslib.de



www.manualslib.es



www.manualslib.fr



www.manualslib.nl



www.manualslib.mx



www.manualslib.tech 30+ Languages